

# BUSINESS PROCESS ANALYSIS

Nivid Informatics Private Limited

Snapshot of Projects Completed  
in last 18 months



## Projects Completed in last 18 months... 1 / 3

---

1. **Modelling & Simulation of Semi-automated Engine Testing Line:** for Leading Equipment Manufacturing company specializing in intelligent production line and intelligent equipment integration
2. **Design Validation & Simulation of a process layout of a Test and Assembly Line (TBU):** for Leading Automation and Robotics Company – 4 projects
3. **Process Reliability Modelling** for World's leading consulting and engineering organization based in UAE – 2 projects
4. **Dynamic Simulation Phase I** for A large process consulting organization based out of Australia & South Africa
5. **Dynamic Simulation Phase II** for A large process consulting organization based out of Australia & South Africa
6. **Logistics Study Simulation Phase I** for A large process consulting organization based out of Australia & South Africa
7. **Process design validation & balancing of an Assembly Line:** for a leading tier-1 auto component company

## Projects Completed in last 18 months... 2 / 3

---

8. **Logistics Study Simulation Phase II** for A large process consulting organization based out of Australia & South Africa
9. **Copper Smelter Simulation** for A large process consulting organization based out of Australia & South Africa
10. **Development of Operations Planning and Analysis tool** for One of the largest independent manufacturers of powertrain and precision-engineered products in India
11. **Development of Digital twin of Shop-floor** for One of the largest Agri-tech & allied products company in India
12. **Simulation Model of LS Line** for Indian subsidiary of one of the leading manufacturers of braking systems and supplier of additional sub-systems for rail and commercial vehicles
13. **Simulation of PCR Tyre Handling System** for One of India's leading Tire brands providing world-class products & services to 100+ countries
14. **Warehouse ASRS Design Validation Management:** For a large automation & robotics org and a large org in Middle East
15. **Warehouse design insights to understand bottleneck:** For a large 3PL company based in Singapore

## Projects Completed in last 18 months... 3 / 3

---

**16. Modelling & Simulation of MultiDeep ASRS** for Leading Automation and Robotics Company

**17. Modelling & Simulation of Adhesives Production Line** for Adhésives Technologies India Pvt. Ltd.

**18. Autonomous Mobile Robot Loops** for Leading Automation and Robotics Company

**19. Simulation of TBU Line (Phase 3)** for Leading Automation and Robotics Company

**20. Simulation of PCR Tyre Handling System (Phase 2)** for One of India's leading Tyre brands providing world-class products & services to 100+ countries

# 1. Modelling & Simulation of Semi-automated Engine Testing Line (4 wk)

Parameter	Description
Customer	Leading Equipment Manufacturing company specializing in intelligent production line and intelligent equipment integration
Project name	Modelling & Simulation of Semiautomated Engine Testing Line
Objective	Development of Digital Twin to determine following. <ul style="list-style-type: none"><li>• Calculate “throughput” for the given layout, process &amp; the data set.</li><li>• Identify the interval between 2 engine loading time, based on the required throughput of *** K units/year &amp; *** K units/year.</li></ul>
Brief scope	<ul style="list-style-type: none"><li>• A simulation model of the proposed design</li><li>• A findings presentation and report from the model and scenarios</li></ul>
Key features	<ul style="list-style-type: none"><li>• Continuous, Basic &amp; Data elements; 180+ elements &amp; 56 parameters</li><li>• MS Excel</li><li>• Power BI</li><li>• Modules, logics, &amp; UFD</li><li>• Unconstrained &amp; Constrained Analysis</li><li>• Charts &amp; Graphs</li><li>• Sensitivity analysis</li></ul>

# 1. Simulation of TBU Line (4 wk)

## Findings

One of the critical findings is show that system blocks after 45,000 minutes due to high cycle time of rework stations.

### Haosen

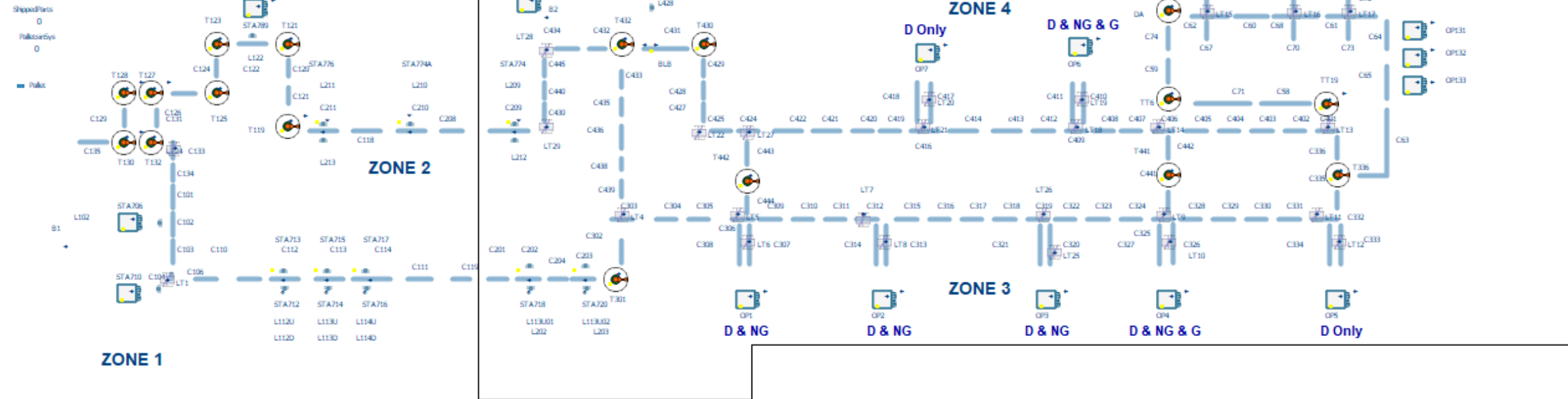

## 2. Simulation of TBU Line (6 wk)

Parameter	Description
Customer	Simulation of TBU Line for Leading Automation and Robotics Company
Project name	Simulation of TBU Line
Objective	<p>Development of Digital Twin to determine following. Line tack time for normal flow; Line tack time considering rejection &amp; down time; Required buffer stopper QTY to achieve required throughput; Total number of pallets required to achieve required throughput; All above conditions to be validated for following variant combination.</p> <ul style="list-style-type: none"><li>• 100% conventional models on line &amp; 100% hybrid engine models on line</li><li>• Combine 50% conventional &amp; 50% hybrid models on line</li></ul>
Brief scope	<ul style="list-style-type: none"><li>• A simulation model of the proposed design</li><li>• A findings presentation and report from the model and scenarios</li></ul>
Key features	<ul style="list-style-type: none"><li>• Continuous, Basic &amp; Data elements; 260+ elements &amp; 68 parameters</li><li>• MS Excel</li><li>• Modules, logics, &amp; UFD</li><li>• Unconstrained &amp; Constrained Analysis</li><li>• Charts &amp; Graphs</li><li>• Sensitivity analysis</li></ul>

## 2. Simulation of TBU Line (6 wk)

### Findings

Simulation results show that for 200 pallets, performance of the line is as per expectations for conventional, hybrid and mix cases. But for 250 pallets, line blocks in hybrid case due to low buffer size.

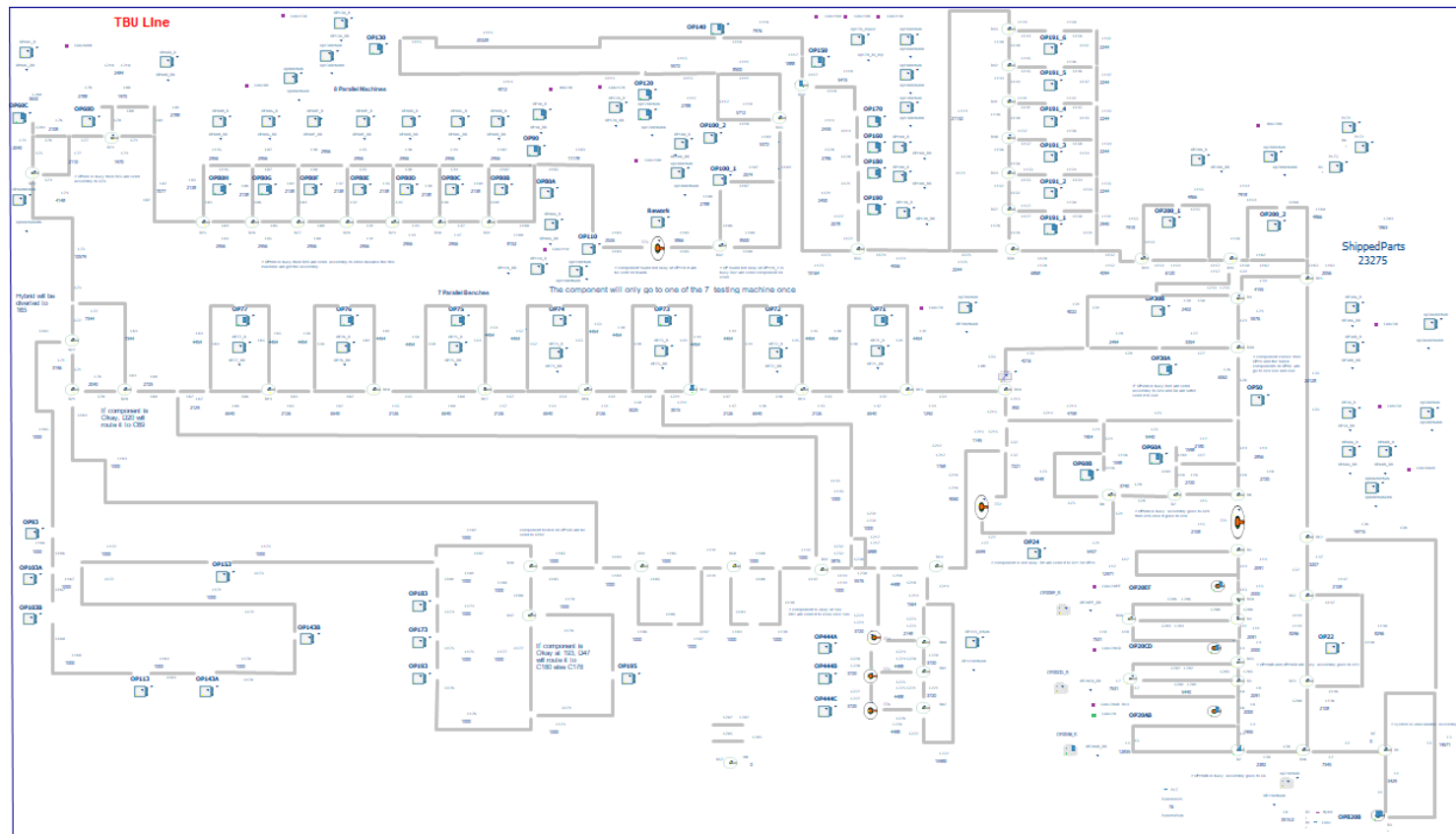



### 3. Process Reliability Modelling (4 wk)

Parameter	Description
Customer	Leading consulting and engineering company operating across Energy and Materials markets
Project name	Process Reliability Modelling
Objective	To carry out Reliability Study to design and install 36' pipelines
Brief scope	<ul style="list-style-type: none"><li>• A simulation model of the proposed design</li><li>• A findings presentation and report from the model and scenarios</li></ul>
Key features	<ul style="list-style-type: none"><li>• Continuous, Basic &amp; Data elements; 50+ elements &amp; 35 parameters</li><li>• MS Excel</li><li>• Modules, logics, &amp; UFD</li><li>• Unconstrained &amp; Constrained Analysis</li><li>• Charts &amp; Graphs</li><li>• What if analysis</li><li>• Sensitivity analysis</li></ul>
Findings	Simulation results show that there is 0.2%-0.65% deviation in reliability, availability and performance of the system form designed over 20 years of life span.

### 3. Process Reliability Modelling (4 wk): (UAE based engg & consulting company)

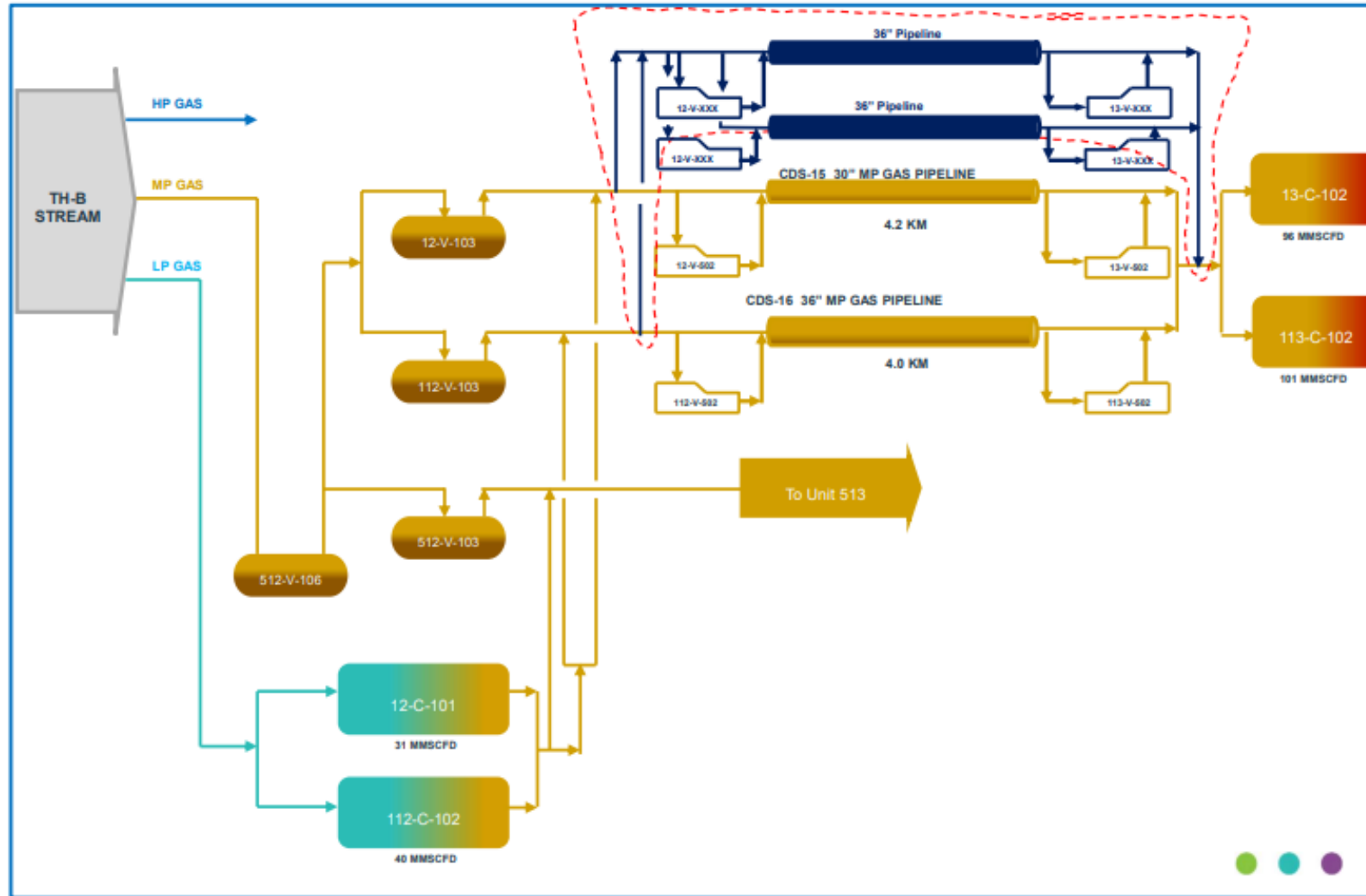

### 3. Process Reliability Modelling (4 wk)

---

- System performance's conformity (productivity) is 99.914% in max. and min. flow cases i.e. Pipeline flowrate (271,891-271,725.12 & 128,144-128,034.34 Kg/hr).
- Simulation results shows that system is highly reliable over span of 20 years of life i.e. System (99.66%-71.40%) in both max. and min. flow cases.
- System Availability is 100% in both max. and min. flow cases .
- Simulation results shows system will face no failure in 20 years of life.
- There are total 5 types of equipment's are in the system. One equipment is critical, and 04 have alternate arrangements (partial flow from pipeline/extra flow from other pipeline).
- Reliability of the critical equipment's is as follows: Pipe line (99.66%-71.40 % , no failure), over span of 20 years of life.
- All 5 equipment's are highly reliable (99.77%-50.76%) with no failure over span of 20 years.
- Maintenance recommendations have been given for all equipments.

## 4. Process Reliability Modelling (6 wk): (UAE based engg & consulting company)

Parameter	Description
Customer	International Engineering and Consulting Firm based on Abu Dhabi
Project name	Process Reliability Modelling
Objective	To carry out Reliability Study to design and install pipelines from the source and the return pipeline(s).
Brief scope	<ul style="list-style-type: none"><li>• A simulation model of the proposed design</li><li>• A findings presentation and report from the model and scenarios</li></ul>
Key features	<ul style="list-style-type: none"><li>• Continuous, Basic &amp; Data elements; 50+ elements &amp; 35 parameters</li><li>• MS Excel</li><li>• Modules, logics, &amp; UFD</li><li>• Unconstrained &amp; Constrained Analysis</li><li>• Charts &amp; Graphs</li><li>• What if analysis</li><li>• Sensitivity analysis</li></ul>
Findings	Simulation results show that there is 3%-5% deviation in reliability, availability and performance of the system form designed over 30 years of life span.

# 4. Process Reliability Modelling (6 wk)

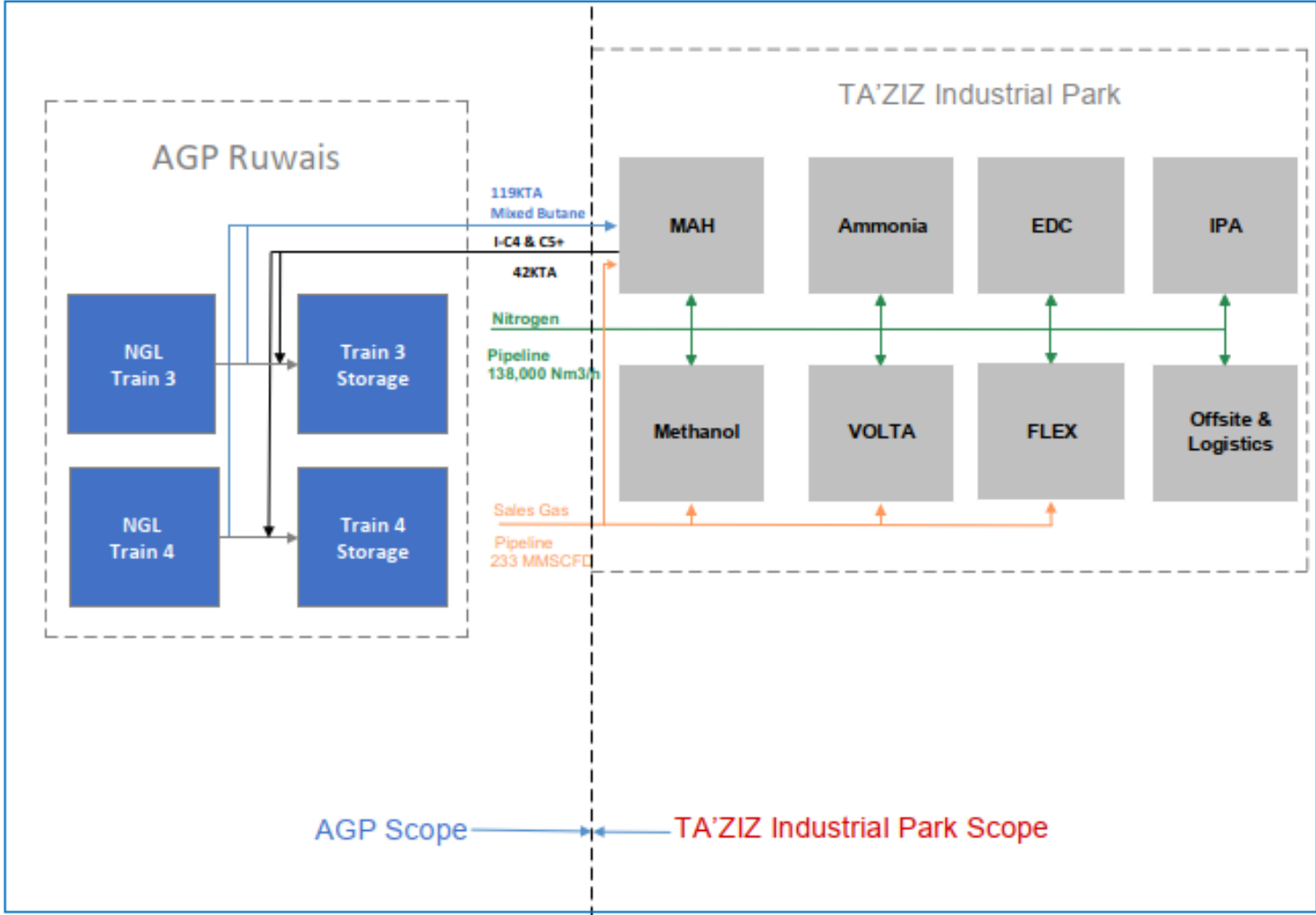

## 4. Process Reliability Modelling (6 wk)

- System (all streams) performance's conformity is 99.938% i.e. Mixed Butane System (119-118.7 KTA), Return Stream (42-42 KTA), Sales Gas (233-233 MMSCD) & Nitrogen (138000-138000 NM3).
- Simulation results shows that system is highly reliable over span of 30 years of life i.e. Mixed Butane System (97.3%-70.65%), Return Stream (99.7%-90.2%), Sales Gas (99.7%-90.2%) & Nitrogen (99.7%-90.2%).
- System Availability is 99.938%.
- There are total 11 types of equipments are used in system. Two equipments are critical, and 09 have alternate arrangements (spare/spare steam/flow from other train).
- Simulation results shows that Mixed Butane stream will face 1 failure (of critical equipment) and other streams will face no failure in 30 years of life.
- Reliability of these two critical equipments is as follows: Pipe line (99.7%-90.2%, no failure), & Surge drum (88.4%-72.63%, 1 failure) over span of 30 years of life .
- Out of 11, over span of 30 years, 6 equipments are highly reliable (99%-51%) with no failure, and 5 equipments are reliable (95.3%-48.9%) with one or two failures. Maintenance recommendations have been given for all **...IS IN SIGHT!** equipments.

## 5. Dynamic Simulation (14 wk) /1

Parameter	Description
Customer	A large process consulting organization based out of Australia & South Africa
Project name	Dynamic Simulation Phase I
Objective	How confident are we in the plant being able to produce the desired output?
Brief scope	<ul style="list-style-type: none"><li>• A simulation model of the proposed Lithium plant</li><li>• A findings presentation and report from the model and scenarios</li></ul>
Key features	<ul style="list-style-type: none"><li>• Continuous, Basic &amp; Data elements; 200+ elements &amp; 127 parameters</li><li>• MS Excel</li><li>• Power BI</li><li>• Modules, logics, &amp; UFD</li><li>• Unconstrained &amp; Constrained Analysis</li><li>• Charts &amp; Graphs</li><li>• What if analysis</li><li>• Sensitivity analysis</li></ul>
Findings	Simulated Product Feed ratio is 1.08 which is less than design mass balance 1.14 due to dust handling systems

# 5. Dynamic Simulation (14 wk) /2

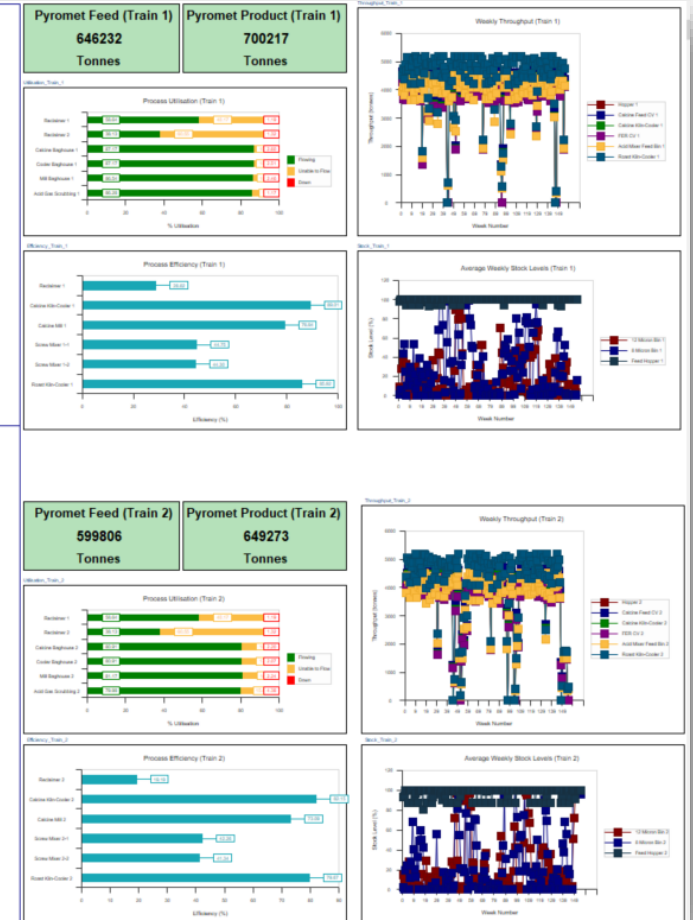
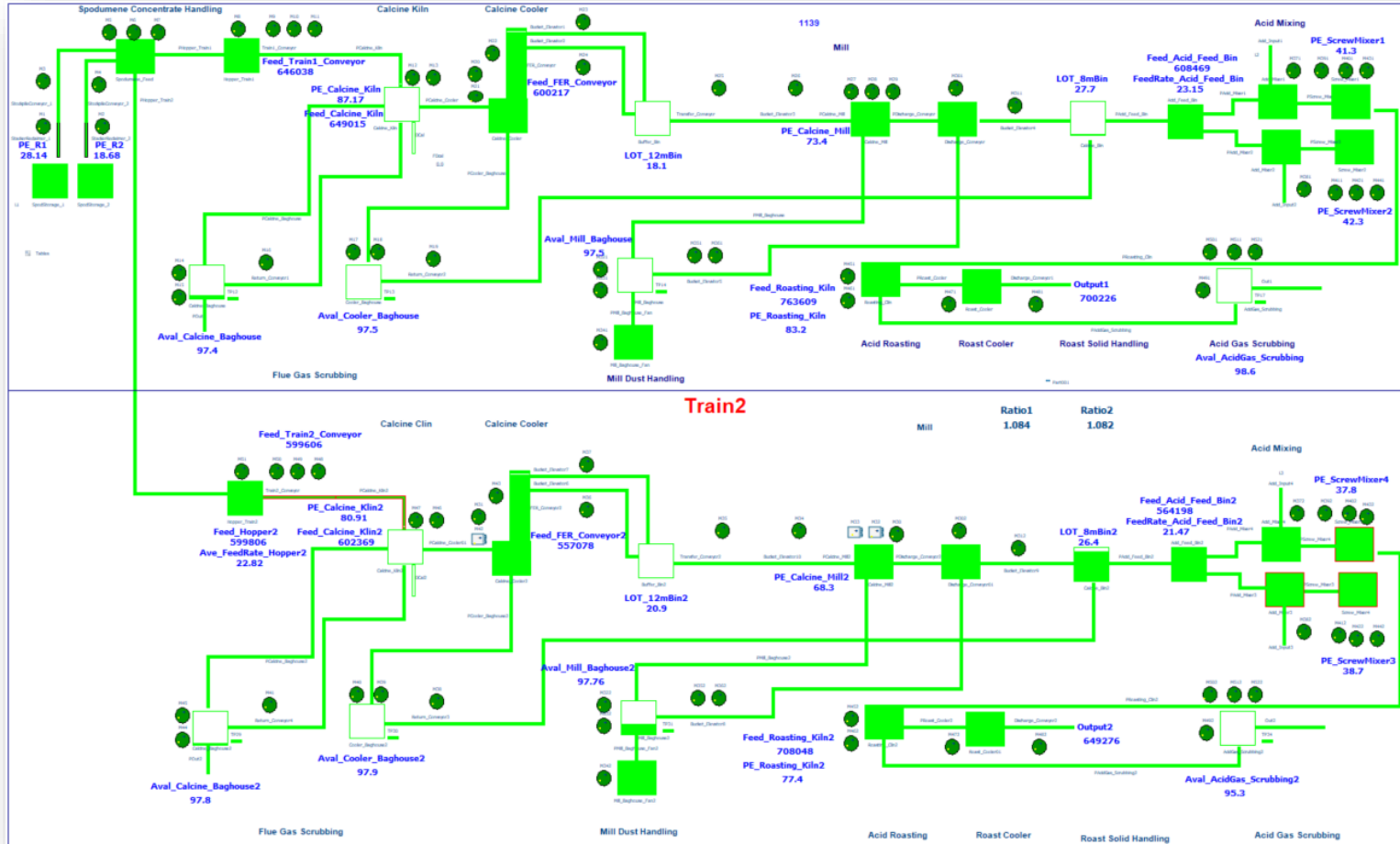



## 6. Models Phase II (11 wk)

Parameter	Description
Customer	A large process consulting organization based out of Australia & South Africa
Project name	Dynamic Simulation Phase II
Objective	Development of consolidate model of the proposed Lithium plant
Brief scope	<ul style="list-style-type: none"><li>• A simulation model of the proposed Lithium plant</li><li>• Capacity analysis</li><li>• A findings presentation and report from the model and scenarios</li></ul>
Key features	<ul style="list-style-type: none"><li>• Continuous, Basic &amp; Data elements; 300+ elements &amp; 179 parameters</li><li>• MS Excel</li><li>• Power BI</li><li>• Modules, logics, &amp; UFD</li><li>• Unconstrained &amp; Constrained Analysis</li><li>• Charts &amp; Graphs</li><li>• What if analysis</li><li>• Monte Carlo analysis</li><li>• Sensitivity analysis</li></ul>

## 6. Models Phase II (11 wk): Results

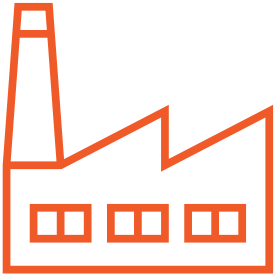

On **average**, it was determined that the pyromet:

- Consumes **236 ktpa of spodumene** and produces **267 ktpa of acidified solids** per train (equivalent to **28.9 ktpa of LHM product**).
- Runs at an **OEE** of approximately **93%**.
- Uses the **standby acid mixers** less than **1%** of the time and demonstrates **equipment unavailability** between **0.4%** and **3.3%** of the time.

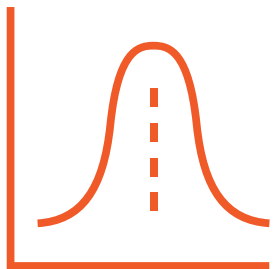

**Monte Carlo** analyses revealed that:

- There is a **100% confidence** that the pyromet will output **sufficient** acidified solids to produce **25 ktpa of LHM product** per train.
- The possible output of **acidified solids** ranges between **253 and 276 ktpa** per train.

## 7. Logistics Study Simulation Phase I (06 wk) /1

Parameter	Description
Customer	A large process consulting organization based out of Australia & South Africa
Project name	Logistics Study Simulation Phase I
Objective	Development of simulation model of the client's logistics
Brief scope	<ul style="list-style-type: none"><li>• Determine the Throughput Capacity</li><li>• Derive the Working Capital Requirements</li><li>• Scenario Testing to Derive Improvements</li></ul>
Key features	<ul style="list-style-type: none"><li>• Basic, Continuous, transport &amp; Data elements; 170+ elements &amp; 109 parameters</li><li>• MS Excel</li><li>• Power BI</li><li>• Modules, logics, &amp; UFD</li><li>• Charts &amp; Graphs</li><li>• What if analysis</li><li>• Monte Carlo analysis</li><li>• Sensitivity analysis</li></ul>

# 7. Logistics Study Simulation Phase I (06 wk) /2

## Vessel Logistics Summary

Period about two months with no vessel haulage.

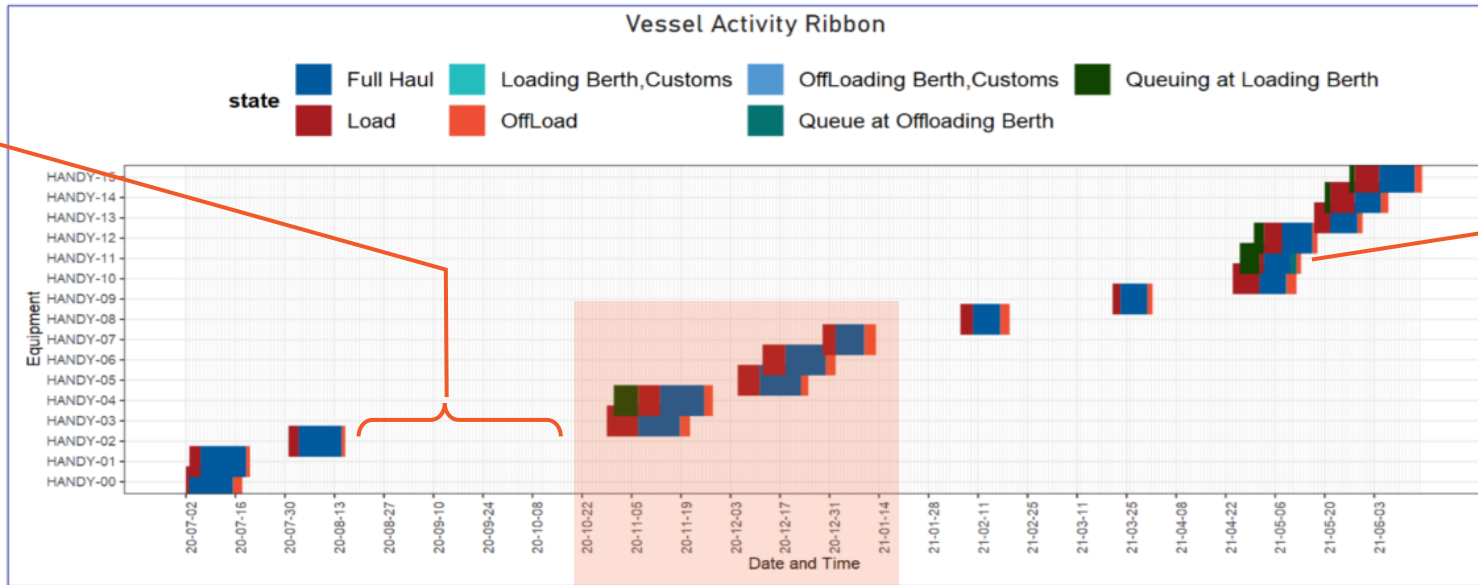

A lot of vessels are scheduled to be loaded between late April – May. This results in noticeable vessel queuing (green bars).

Turn around time to ship spodumene to China fluctuates between 11 and 24 days.

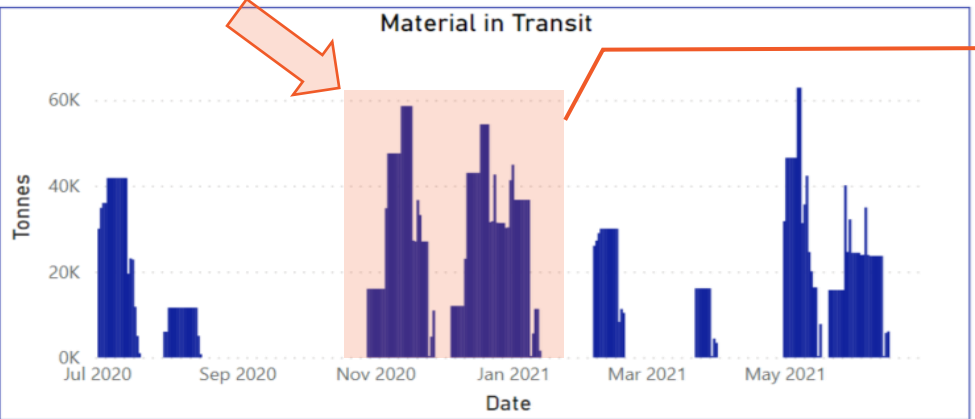
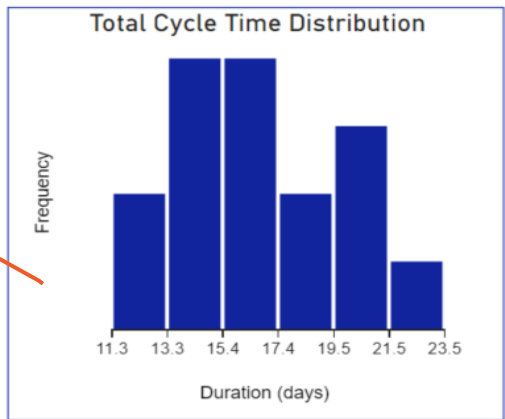

A lot of material (approx. 94 000 tonnes of LG) is shipped between November 2020 and January 2021

## 8. Logistics Study Simulation Phase I (06 wk)

Parameter	Description
Customer	A large process consulting organization based out of Australia & South Africa
Project name	Logistics Study Simulation Phase II
Objective	Development of simulation model of client's revised logistics
Brief scope	<ul style="list-style-type: none"><li>• Additions to Model: Wodgina Mine → Port Hedland → China; ZJG Plant; Meishan Plant; ZJG Warehouse</li><li>• Removed from the Model: Chengdu Plant</li><li>• Determine the Throughput Capacity</li><li>• Derive the Working Capital Requirements</li><li>• Scenario Testing to Derive Improvements</li></ul>
Key features	<ul style="list-style-type: none"><li>• Basic, Continuous, transport &amp; Data elements; 216+ elements &amp; 146 parameters</li><li>• MS Excel</li><li>• Power BI</li><li>• Modules, logics, &amp; UFD</li><li>• Charts &amp; Graphs</li><li>• What if analysis; Monte Carlo analysis; Sensitivity analysis</li></ul>

## 9. Copper Smelter Simulation (08 wk)

Parameter	Description
Customer	A large process consulting organization based out of Australia & South Africa
Project name	Copper Smelter Simulation
Objective	Development of simulation model of Copper Smelter Plant
Brief scope	<ul style="list-style-type: none"><li>• A simulation model of Copper Smelter Plant</li><li>• A findings presentation and report from the model and scenarios</li></ul>
Key features	<ul style="list-style-type: none"><li>• Basic, transport Continuous, &amp; Data elements; 97+ elements &amp; 84 parameters</li><li>• MS Excel</li><li>• Power BI</li><li>• Modules, logics, &amp; UFD</li><li>• Charts &amp; Graphs</li><li>• What if analysis</li><li>• Sensitivity analysis</li></ul>

# 10. Development of Operations Planning and Analysis Tool (16 wk)

Parameter	Description
Customer	One of the largest independent manufacturers of powertrain and precision-engineered products in India
Project name	Development of Operations Planning and Analysis tool for efficient Monitoring and Control
Objective	Developing a simulation model for key operations of soft line and perform "What-if" analysis to gain insight into the effects of critical factors
Brief scope	<ul style="list-style-type: none"><li>• Develop a simulation model for a representative part of soft line operations with an emphasis on Production Scheduling, Machines failures, Maintenance plan, Inventory plan, &amp; Quality plan</li><li>• Performing "What -If" analysis (lead time, batch sizing, inventory level, manpower plan, etc.) and associated variability for efficient decision making</li><li>• Exploring the possibility and usefulness of integrated operations planning under uncertainty for better system performance</li></ul>
Key features	<ul style="list-style-type: none"><li>• Basic, transport &amp; Data elements; 317+ elements &amp; 179 parameters, 84 variables</li><li>• MS Excel</li><li>• Logics, &amp; UFD</li><li>• Charts &amp; Graphs; What if analysis; Optimization; Sensitivity analysis</li></ul>

# 10. Development of Operations Planning and Analysis Tool (16 wk)

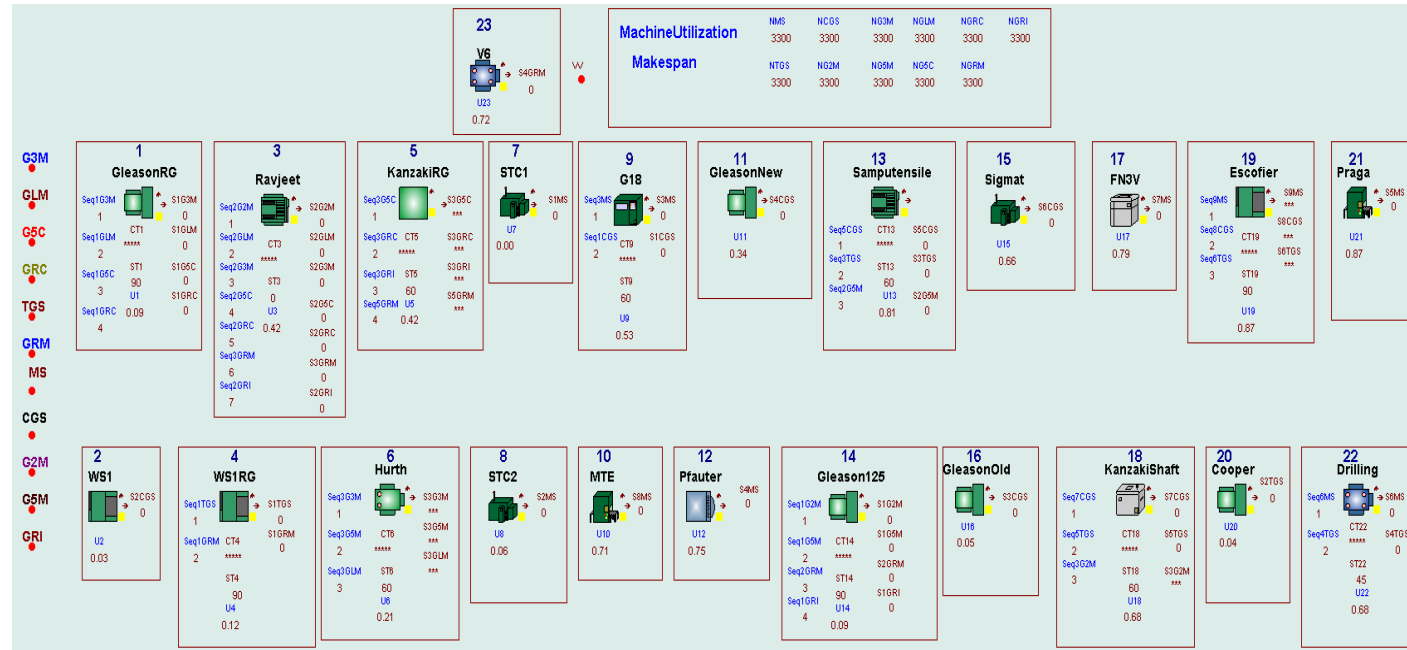

KPI	Operations planning (Experience based)	Operations planning (Simulation)
Completion time	30 Days	25 days
Throughput	32,600	36,300
On-time delivery	87%	100%

- 16.7%

+ 11.3%

+ 14.9%



# 11. Development of Digital twin of Shop-floor (12 wk)

Parameter	Description
Customer	One of the largest Agri-tech & allied products company in India
Project name	Development of Digital twin of Shop-floor
Objective	To generate a method for sequencing the variants with optimal batch size, such that the total make-span time is minimized
Brief scope	<ul style="list-style-type: none"><li>• Development of simulation model</li><li>• Forecasting bin model</li><li>• Decision-making tool</li></ul>
Key features	<ul style="list-style-type: none"><li>• Basic, transport &amp; Data elements; 155+ elements &amp; 117 parameters, 59 variables</li><li>• MS Excel</li><li>• Logics, &amp; UFD</li><li>• Charts &amp; Graphs; What if analysis; Optimization; Sensitivity analysis</li></ul>

## 12. Simulation Model of LS Line 2 (Pilot Project) (02 wk)

Parameter	Description
Customer	Indian subsidiary of one of the leading manufacturers of braking systems and supplier of additional sub-systems for rail and commercial vehicles
Project name	Simulation Model of LS Line 2 (Pilot Project)
Objective	Development of Simulation model of LS Line 2
Brief scope	<ul style="list-style-type: none"><li>• A simulation model of the line</li><li>• Capacity analysis</li></ul>
Key features	<ul style="list-style-type: none"><li>• Basic, transport &amp; Data elements; 64+ elements &amp; 37 parameters, 25 variables</li><li>• MS Excel</li><li>• Logics, &amp; UFD</li><li>• Charts &amp; Graphs; What if analysis; Optimization; Sensitivity analysis</li></ul>

# 13. Modelling & Simulation of Multiple Automation Proposals

Parameter	Description
Customer	One of India's leading Tire brands providing world-class products & services to 100+ countries
Project name	Simulation PCR Tyre Handling System
Objective	Capital Expenditure Assessment
Brief scope	<ul style="list-style-type: none"><li>• Simulation Models + Excel Spreadsheet of the Final Model &amp; all analysis data</li><li>• Derive the quantity &amp; configuration/setup of Gantry Tools</li><li>• Simulation model developed that is inclusive of ideas from the organisation &amp; proposals from automation vendors for de-bottlenecking the area.</li><li>• Specifications &amp; quantified justification for change relative to set of options in the models</li></ul>
Key features	<ul style="list-style-type: none"><li>• Use of conveyors, PF sections, Logic mapping for turn-tables and providing excel interface for what-if scenarios Process characteristics such as flow logic, manual interventions, triggers for setups/breakdowns, cycle time, takt-time &amp; other properties.</li><li>• Machine Configuration, Lay-out etc.</li></ul>

# Warehouse ASRS Design Validation

Parameter	Description
Customer	Leading Automation and Robotics Company
Project name	Simulation of MultiDeep-ASRS design
Objective	Ensure the system is designed to process the throughput of 176 pallets / hour as infeed and deliver 176 pallets / hour at outfeed. This includes 10% buffer, for varying frequency of inputs.
Brief scope	Determine KPIs (Throughput, Warehouse availability / Utilization ratio, and System Utilisation / Availability) <ul style="list-style-type: none"><li>• Simulation of scenario of ordering the SKUs 2/3 times / week / batch size</li><li>• SKU mix 30% Localization - Shift Pick + 70% 3 time/Week/Batch Size (30%+70%)</li><li>• SKU mix 30% Localization - Daily Pick + 70% 3 time/Week/Batch Size (30%+70%)</li></ul>
Key features	<ul style="list-style-type: none"><li>• Continuous, Basic &amp; Data elements; 260+ elements &amp; 68 parameters</li><li>• MS Excel interface</li><li>• Modules, logics, &amp; UFD</li><li>• Unconstrained &amp; Constrained Analysis</li><li>• Sensitivity analysis</li></ul>

# Witness model with defined flow and logic

## ASRS Storage

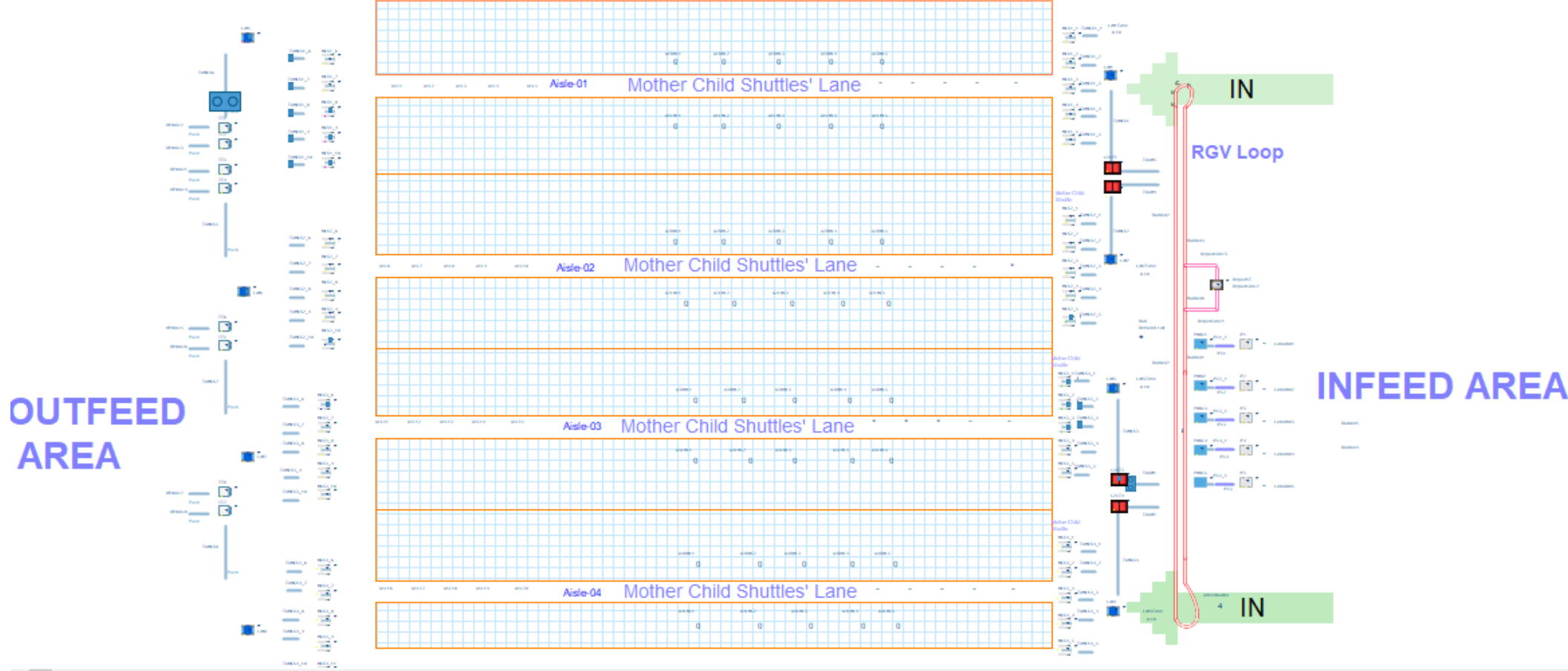

# Simulation and optimization of Warehouse

Parameter	Description
Customer	Large 3PL company based in Singapore
Project name	Simulation of Warehouse design
Objective	<ul style="list-style-type: none"><li>• Aisles are blocked due to WIP build-up at pre &amp; post packing. This is creating inefficient accessibility to storage, packing stations and shipping areas.</li><li>• Therefore, it was important to determine the effect of critical process variables such as number of carriers, processing times and number of stations on WIP.</li></ul>
Brief scope	<p>Determine KPIs for below Simulation scenarios.</p> <ul style="list-style-type: none"><li>• What if - we increased the number of processing stations?</li><li>• What if - we change process parameters?</li><li>• What if - we increased number of carriers between station?</li><li>• What if - we change the parameters of the carriers?</li></ul>
Key features	<ul style="list-style-type: none"><li>• Continuous, Basic &amp; Data elements; 260+ elements &amp; 68 parameters</li><li>• MS Excel interface</li><li>• Modules, logics, &amp; UFD</li><li>• Unconstrained &amp; Constrained Analysis</li><li>• Sensitivity analysis</li></ul>

# Results for different combinations of varying number of workstations

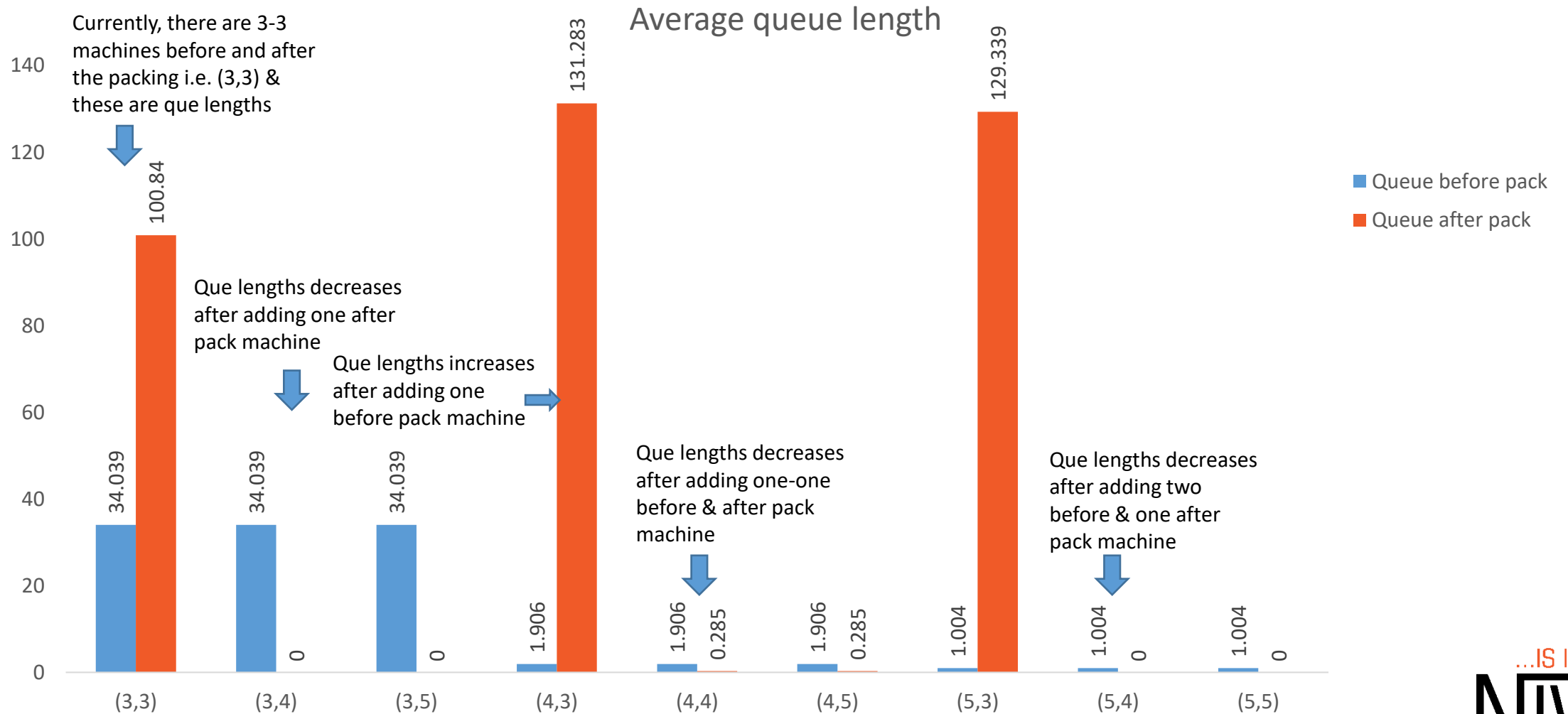

# Results for different processing times

Average queue length for different processing times

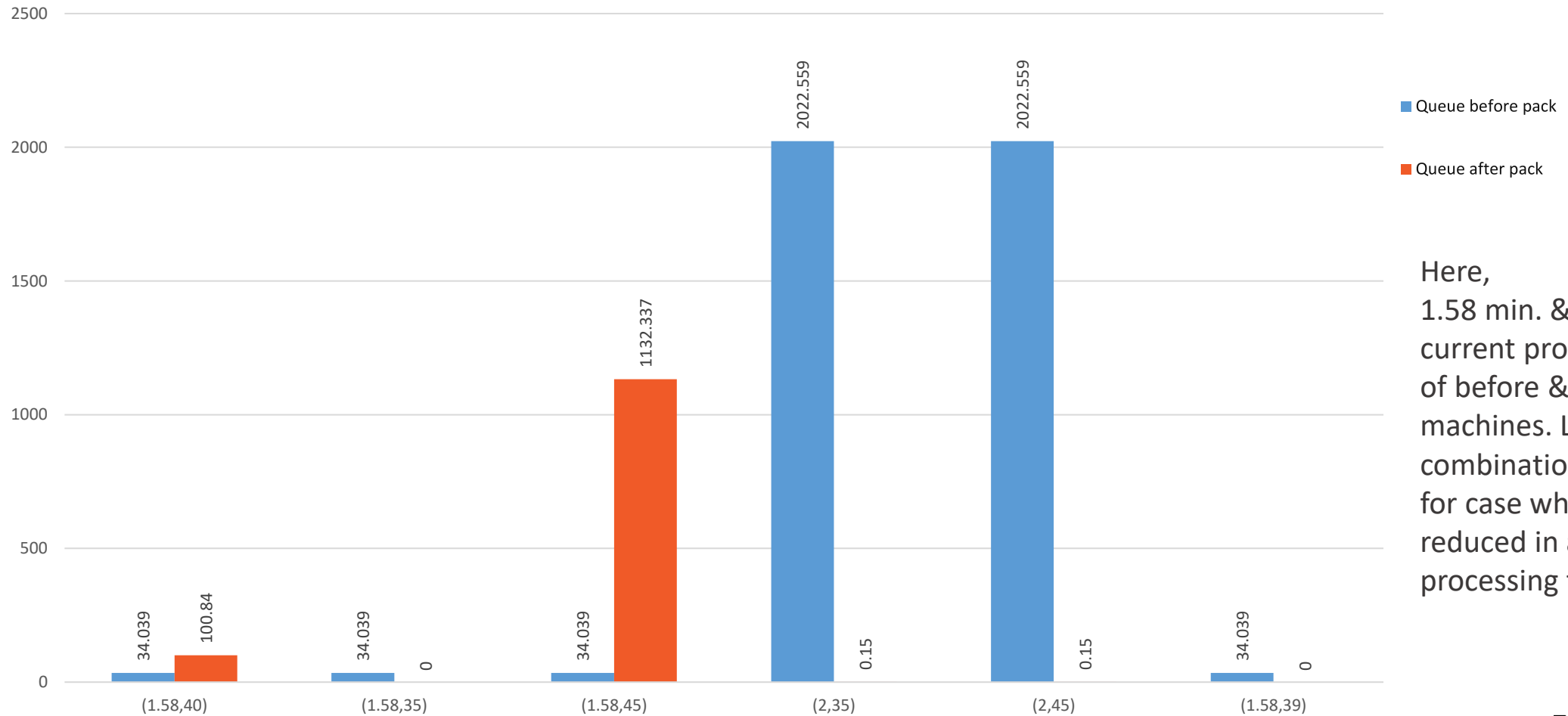

Here, 1.58 min. & 40 min. are current processing time of before & after pack machines. Least queue combination is found for case where 1 min. is reduced in after pack processing time.



# Results by changing number of Carriers

Average queue length for different number of carriers

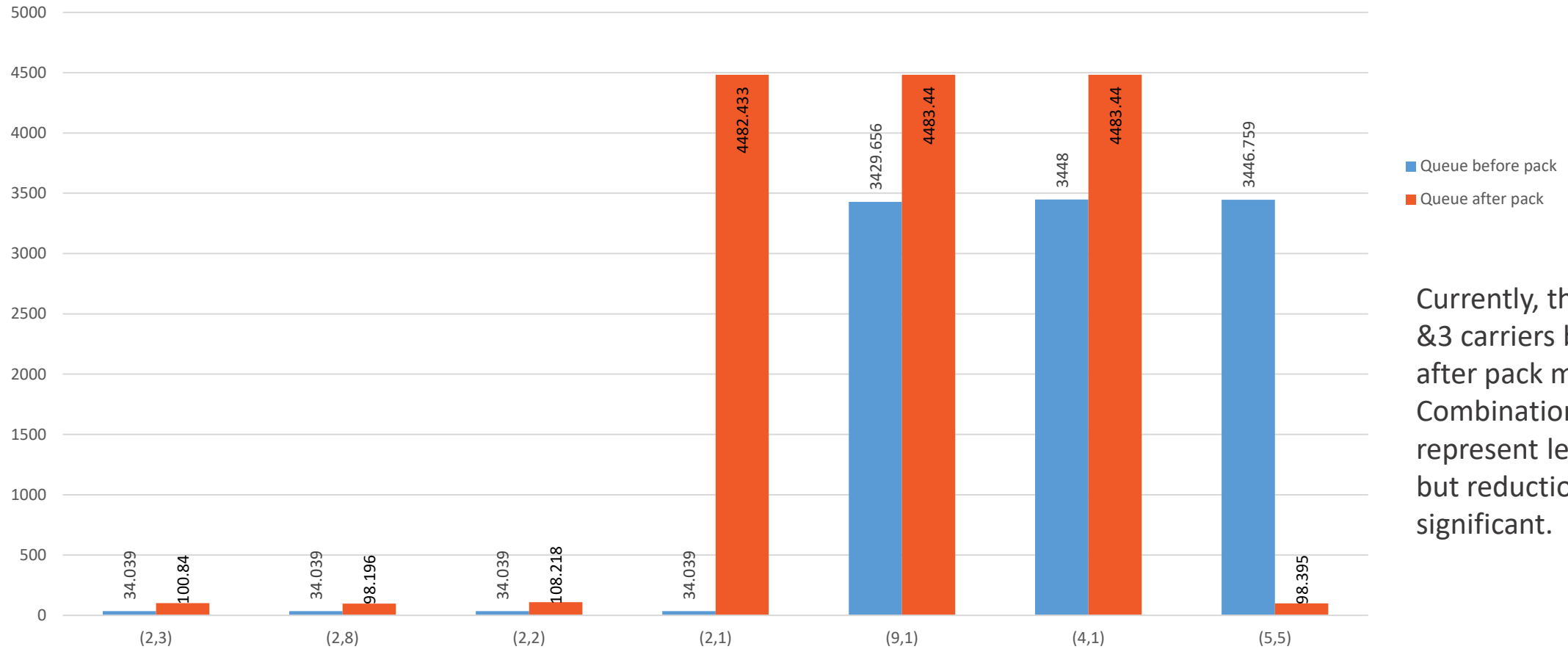

Currently, there are 2 & 3 carriers before and after pack machines. Combination (2,8) represent least queue, but reduction is not significant.

# 16. Modelling & Simulation of Multi-Deep Warehouse using ASRS

Parameter	Description
Customer	Leading Automation and Robotics Company
Project name	PS5580-9118_R07_MultiDeep ASRS
Objective	Modelling & Simulation of Multi-Deep WH with ASRS
Brief scope	<ul style="list-style-type: none"><li>• Build system model using process flow and rules</li><li>• Validation of AS-IS (proposed) system</li><li>• Determine KPIs (Throughput, Warehouse availability /Utilization ratio, and System Utilization / Availability)</li><li>• Simulation of scenario of ordering the SKUs 2/3 times / week /batch size</li><li>• 30% Localization - Shift Pick + 70% 3 time/Week/Batch Size</li><li>• 30% Localization - Daily Pick + 70% 3 time/Week/Batch Size</li></ul>
Key features	<ul style="list-style-type: none"><li>• MS Excel Interface</li><li>• Modules, logics, &amp; UFD</li><li>• Digital twin for Complex system (45000 storage locations)</li><li>• Charts &amp; Graphs</li><li>• What if analysis</li><li>• Sensitivity analysis</li></ul>

# 16. Modelling & Simulation of Multi-Deep ASRS

## Findings

System is capable of handling desired infeed and out feed with warehouse and system utilization of 90% and 65% respectively.

## ASRS Storage

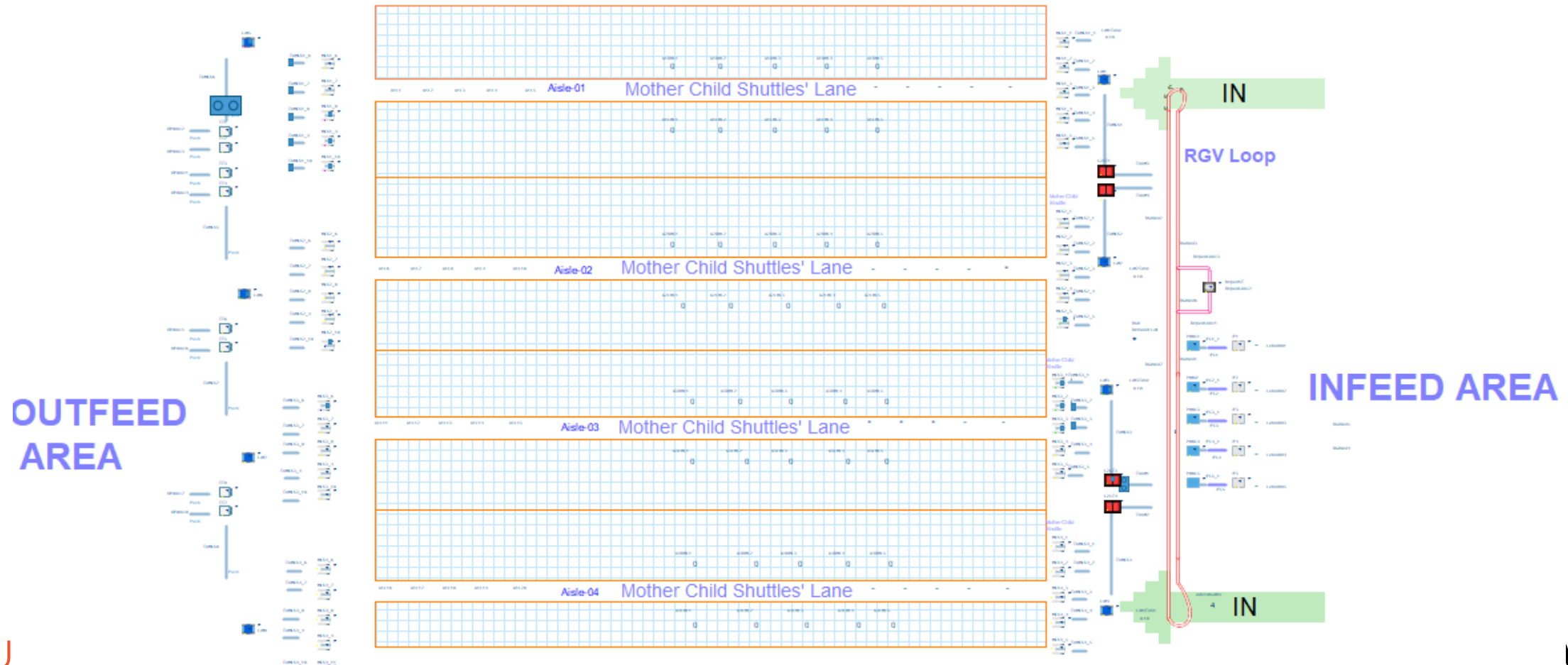

# 17. Modelling & Simulation of 5 Adhésives Production Lines for a World Leading Chemical Company

Parameter	Description
Customer	A World Leading Chemical Company (Adhésives production lines)
Project name	Project R
Objective	Modelling & Simulation of manufacturing line, determine process metrics, bottleneck identification
Brief scope	<ul style="list-style-type: none"><li>• Development of virtual replica (2D) of the system. Brief description of the system</li><li>• Throughput analysis, what if analysis/ stress case scenarios, material handling analysis, machine utilization/ bottleneck analysis, material flow analysis &amp; reporting</li></ul>
Key features	<ul style="list-style-type: none"><li>• MS Excel Interface</li><li>• Basic, transport &amp; Data elements</li><li>• Unconstrained &amp; Constrained Analysis</li><li>• Charts &amp; Graphs</li><li>• What if analysis</li><li>• Sensitivity analysis</li></ul>

# 17. Modelling & Simulation of 5 Adhésives Production Lines for a World Leading Chemical Company

- Findings
- Raw materials consumption in 20 working days is 48,092.52 KG ~48 tons.
  - The warehouse can store 90 days of raw materials.
  - FG out frequency considering the capacity – 2.5 Shifts
  - Warehouse labour utilization is 54.88%.
  - One BOPT is required to transfer raw materials from warehouse to kitting areas

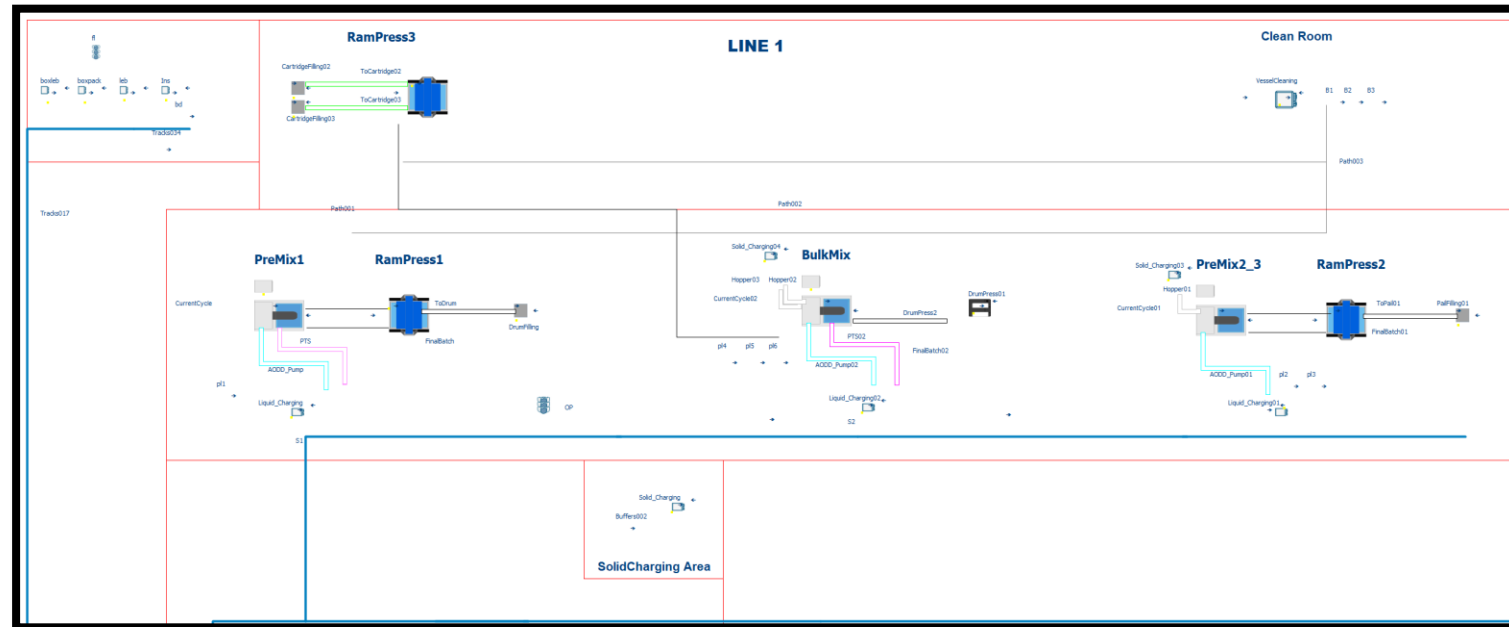

# 18. Modelling & Simulation of Autonomous Mobile Robot (AMR) Loops

Parameter	Description
Customer	Leading Automation and Robotics Company
Project name	PS8487_AMR Loops
Objective	Modelling & Simulation of Autonomous Mobile Robot Loops, determine optimal number of AMRs & charging stations
Brief scope	<ul style="list-style-type: none"><li>• Development of virtual replica (2D) of the system.</li><li>• Optimize number of AMRs for each loop, charging points, for 85% &amp; 70% utilization cases</li><li>• Throughput analysis</li></ul>
Key features	<ul style="list-style-type: none"><li>• MS Excel Interface</li><li>• Basic, transport &amp; Data elements</li><li>• Digital twin for complex system (50 transfer loops, 400 pickup and drop locations)</li><li>• Charts &amp; Graphs</li><li>• What if analysis</li><li>• Sensitivity analysis</li></ul>

# 18. Modelling & Simulation of Autonomous Mobile Robot (AMR) Loops

- Findings
- Total 292 & 349 AMRs will be required to ensure efficient AMR operations without delays with AMRs' effective usage of 85% & 70%, respectively.
  - Total 99 & 108 Charging stations will be required to ensure efficient AMR operations without delays with AMRs' effective usage of 85% & 70% respectively.

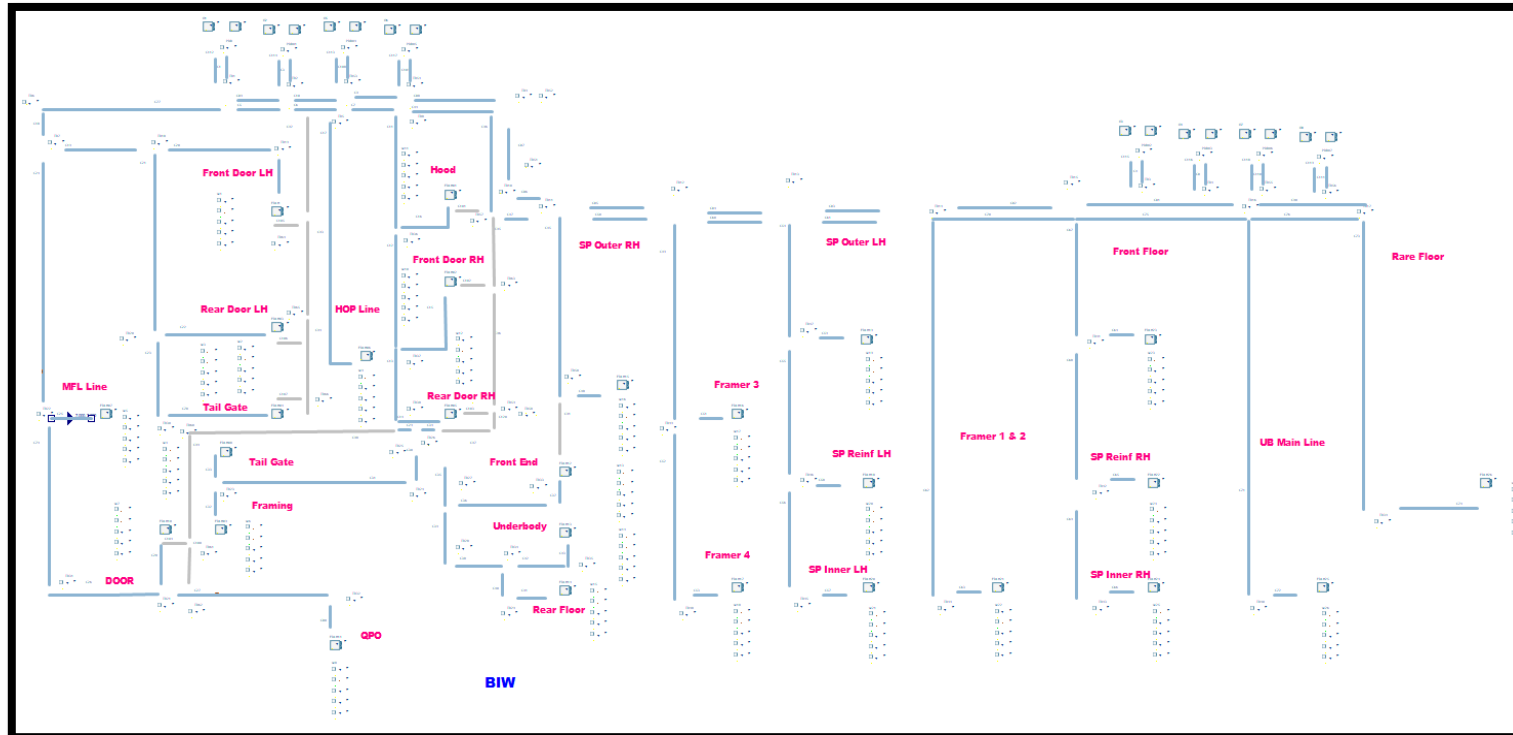

# 19. Simulation of TBU Line (Phase 3)

Parameter	Description
Customer	Simulation of TBU Line for Leading Automation and Robotics Company
Project name	Simulation of TBU Line
Objective	<p>Development of Digital Twin to determine following.</p> <ul style="list-style-type: none"> <li>▪ Change is equipment downtime logic and timing</li> <li>▪ Change is rework logic and timing at OP444 &amp; OP24</li> <li>▪ Addition of scrap percentage</li> <li>▪ Change in shift time</li> <li>▪ Equipment maintenance need to be considered for OP20 operations</li> </ul>
Brief scope	<ul style="list-style-type: none"> <li>• A simulation model of the proposed design</li> <li>• A findings presentation and report from the model and scenarios</li> </ul>
Key features	<ul style="list-style-type: none"> <li>• Continuous, Basic &amp; Data elements; 260+ elements &amp; 68 parameters</li> <li>• MS Excel</li> <li>• Power BI</li> <li>• Modules, logics, &amp; UFD</li> <li>• Unconstrained &amp; Constrained Analysis</li> <li>• Charts &amp; Graphs</li> <li>• What if analysis</li> <li>• Sensitivity analysis</li> </ul>



# 19. Simulation of TBU Line (Phase 3)

- Findings
1. When rework time is reduced to 300 sec., throughputs increase to 20,298 & 20,286 for no. of pallets 325 & 350, respectively.
  2. When rework/rejection percentage is reduced to 1/3, throughputs increase to 20,207 for no. of pallets 325 & 350, respectively.
  3. When rework/rejection percentage is reduced to 1/2, throughputs increase to 16,202 for no. of pallets 325 & 350 respectively.
  4. When rework/rejection time percentage of OP24 & OP444 reduced by 30% & 20% respectively, and rejection rate of OP20 is reduced by 50%, throughput is 19,261 for no. of pallets 325, 350 & 400.

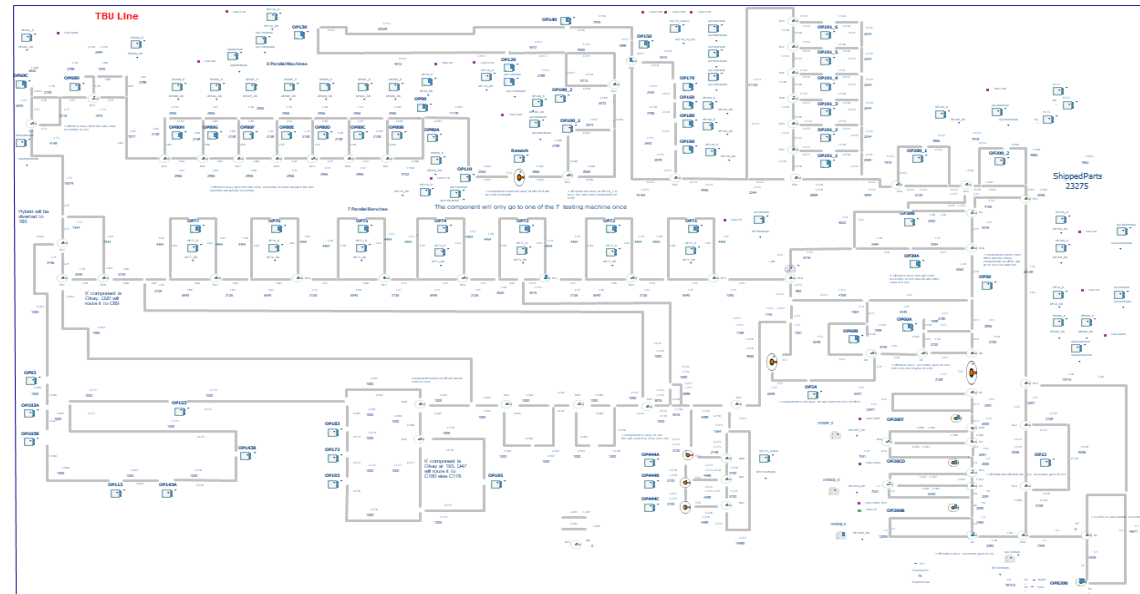

## 20. Simulation of Tyre Production Line (Phase 2)

Parameter	Description
Customer	Simulation of Tyre Production Line for Leading Automation and Robotics Company
Project name	Simulation of Tyre Production Line
Objective	To have the digital twin of the system. To calculate the throughput for 1 week. To calculate the TAKT time.
Brief scope	<ul style="list-style-type: none"><li>• A simulation model of the proposed design</li><li>• A findings presentation and report from the model and scenarios</li></ul>
Key features	<ul style="list-style-type: none"><li>• MS Excel Interface</li><li>• Power BI</li><li>• Modules, logics, &amp; UFD</li><li>• Unconstrained &amp; Constrained Analysis</li><li>• Charts &amp; Graphs</li><li>• What if analysis</li><li>• Sensitivity analysis</li></ul>

# 20. Simulation of Tyre Production Line

- Findings
- The total throughput achieved is 1,21,680 Tyres / Month.
  - 181.07 tyres per hour. Grade 1 : 35,558 tyres, Grade 2 : 29,902 tyres, Grade 3 : 25,723 tyres, Without Grade : 30,497 tyres
  - Rejections and reinserted tyres: VI stations : 10545 tyres, UFM stations : 16918 tyres.

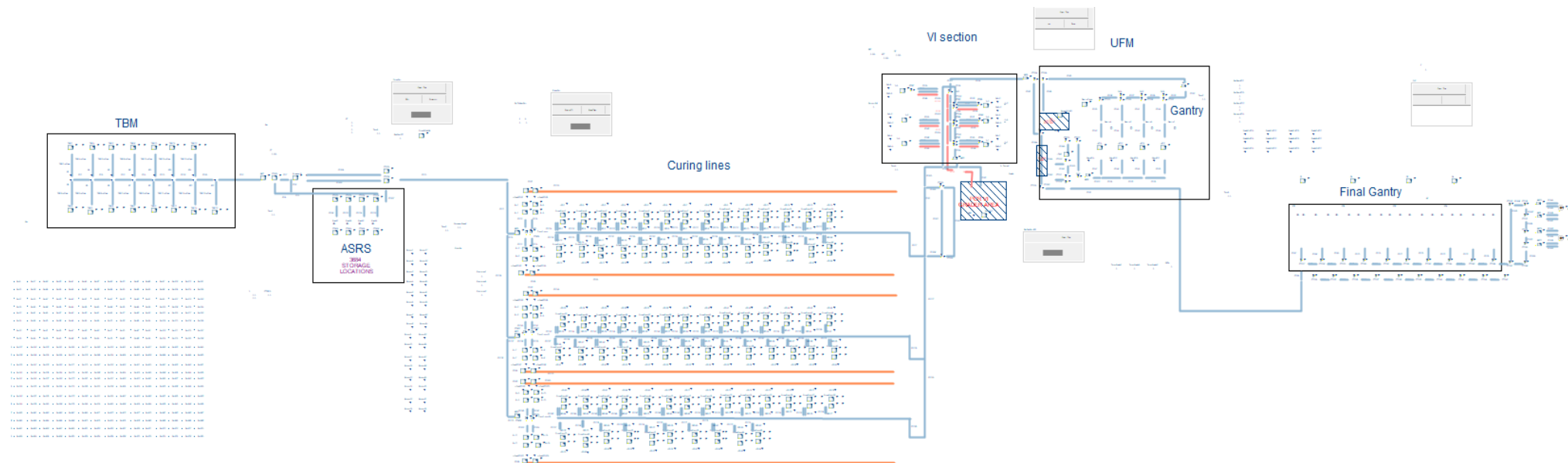

Thank You

BUSINESS PROCESS ANALYSIS

INSIGHT... **NIVID** ...IS IN SIGHT!  
INFORMATICS PRIVATE LIMITED